



HONOADOOR

User Manual

Table of contents

Important safety instructions	3
Use of the equipment	3
Introduction	4
General description	4
Features	5
Installation	7
Connection	7
Electric lock or suction cups	8
Configuration	9
Connect to the Internet	9
Configuration with cloudAssistant	10
<i>Registering the equipment</i>	10
<i>Registering groups and users</i>	13
<i>Configure relays and assign traffic schedules</i>	17
<i>Set group schedules</i>	18
<i>Administration: Honoa</i>	19
Events	20
Operational mode	21
Remote control from cloudAssistant	21
Anti-Passback	22
Settings in cloudAssistant	25
Verification	26
LED behaviour	26
Solving problems	27
Resolve reception issues	27
Technical data	28
Regulatory Data	28
UKCA Declaration of conformity	28
EU Declaration of conformity	28

Important safety instructions



Disconnect the power supply whenever you proceed to the installation or repair of the equipment.

In compliance with the European Low Voltage Directive, we inform you of the following requirements:

- When the devices remain permanently connected, an easily accessible connecting device must be incorporated into the wiring.
- This system must only be installed by qualified professionals that have with automated garage doors and knowledge of the relevant European standards.
- The user instructions for this device must always be in the user's possession.
- The operating frequency of the receiver does not interfere in any way with the 868 MHz remote control systems.

Use of the equipment

This device is designed for applications with an automated garage door. It is not guaranteed for the direct activation of devices other than those specified. The manufacturer reserves the right to change the device specifications without warning. No liability can be accepted for errors and misprints.

Introduction

General description

HONOADOOR is a Motion and Bluetooth receiver connected with **information on the state of the door and with remote activation in real time**.

Save on commutes and secure your installation. Open the door with the phone thanks to the HONOA APP or with the fob.

Along with **cloudAssistant**, you can use HONOADOOR to instantly check the door's operation from your office, avoiding unnecessary trips to check that installations are working properly and to detect and manage suspicious fobs.

The device can work without an Internet connection, but it does require a connection for certain functions.

An Internet connection is required for:

- Setting up the device in **cloudAssistant**:
 - Setting and assigning time slots with the annual holiday calendar
- Checking the entry status in **cloudAssistant**
- Reading events in **cloudAssistant**
- Remote activation of the device with the HONOA APP
- Registering and cancelling fobs
- Alerts and notifications

No Internet connection is required for:

- Setting up the device in **cloudAssistant**:
 - Name of the device that appears on the HONOA APP
 - Name of the relay that appears on the HONOA APP
 - Activating entrances and their settings
- Granting and revoking access permission on **cloudAssistant** for HONOA users
- Deactivating remote opening in HONOA through **cloudAssistant**
- Deactivating Bluetooth hands-free activation in HONOA through **cloudAssistant**

All changes to authorizations or settings in **cloudAssistant** shall be automatically updated in the HONOA APP.

For the HONOA APP to work properly on your phone, in addition to other requirements, you must authorize the use of phone data, access to your location, and to work in the background.

The application does not require an Internet connection to activate the door.

Settings are adjusted through the **cloudAssistant** (v4 or later) with a Internet connection.



Features

Power supply: The equipment is powered with a 110Vac to 230Vac voltage. 500mA protective fuse.

Relay Output: The equipment has 2 adjustable open or closed contact relay outputs. These outputs can be programmed to be activated with different fob channels through **cloudAssistant**. Moreover, these relays can be remotely activated in real time with the **cloudAssistant**.

Inputs: The equipment has 2 inputs to connect 2 limit switches to monitor the door's status (Open/Closed).

868MHz MOTION receiver module: The equipment has an 868MHz MOTION receiver module to receive from fobs.

Bluetooth receiver module: The equipment has a Bluetooth receiver module to open the door in hands-free mode with a phone with the HONOA APP. **Hands-free activation** (BETA function) may be disabled for the entire device in **cloudAssistant**.

GSM Module: The equipment has a GSM communication module for connection to the Internet and for remote opening with a phone with the HONOA APP. **Remote opening** may be disabled for the entire device in **cloudAssistant**.

Users: Up to 5000 users managed with **cloudAssistant**.

Events: Up to 2000 events may be viewed through **cloudAssistant**. Service available expansion to 5000 events.

Statistics and information on use: You may use **cloudAssistant** to view a daily graph of the number of relay activations, accepted and rejected users, open-door and closed-door events, data consumption, and more.

Light-up signals: The equipment has three LED indicators: "ST", "NW", and "IN" to indicate the **cloudAssistant** connection status.

More information



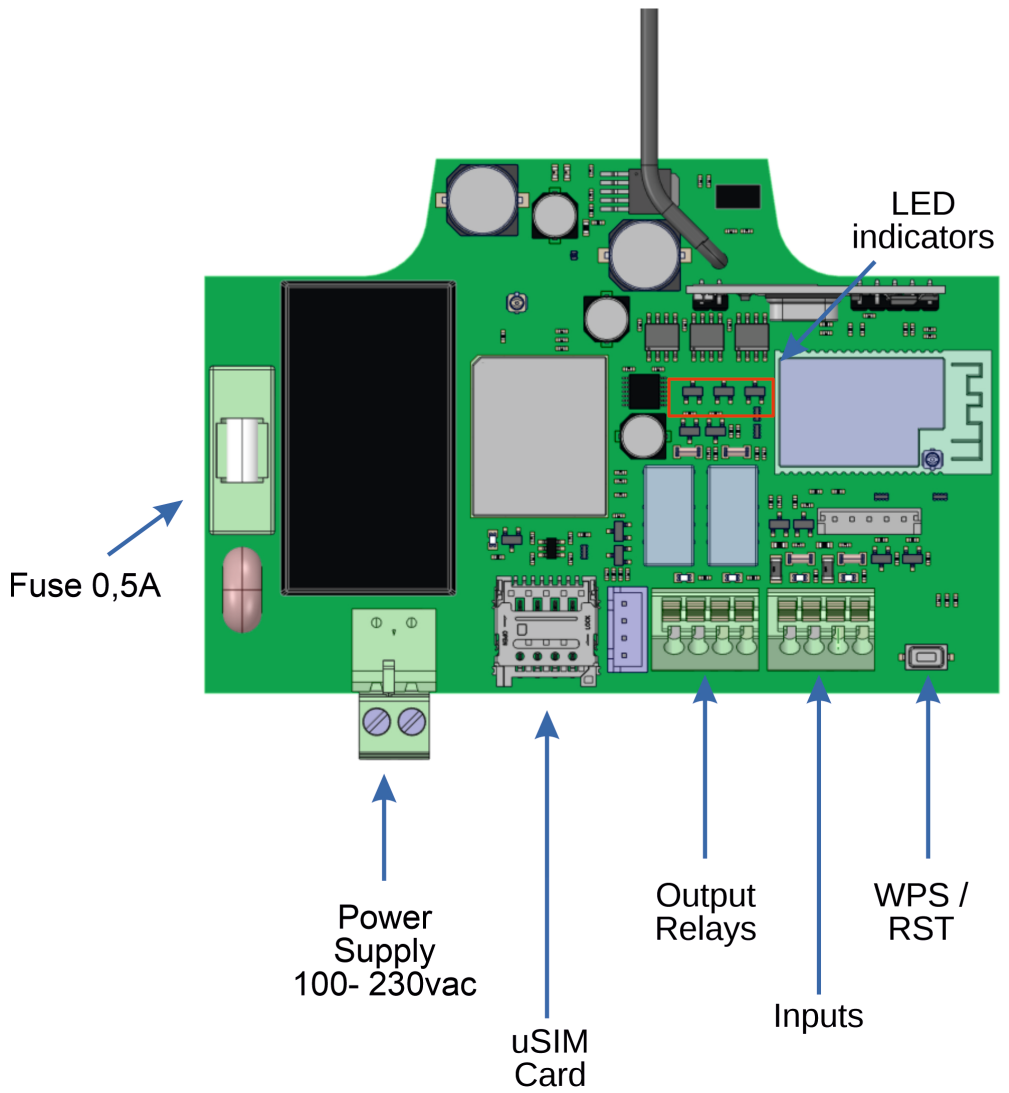

Installation

Attach the back of the box to the wall with the plugs and screws supplied.

Connect the equipment. Attach the front of the receiver to the back part with the screws supplied for this purpose.

Connection

POWER INPUT: Power supply at 230Vac.

R1: RELAY Channel 1. Potential-free contact.

R2: RELAY Channel 2. Potential-free contact

- Characteristics of output relays (for resistive load):
- Maximum current: 2A.
- Maximum power: 60W / 62.5VA.
- Maximum voltage: 24V ac/dc.

IN1: Monitoring input for NC contact.

IN2: Monitoring input for NC contact.

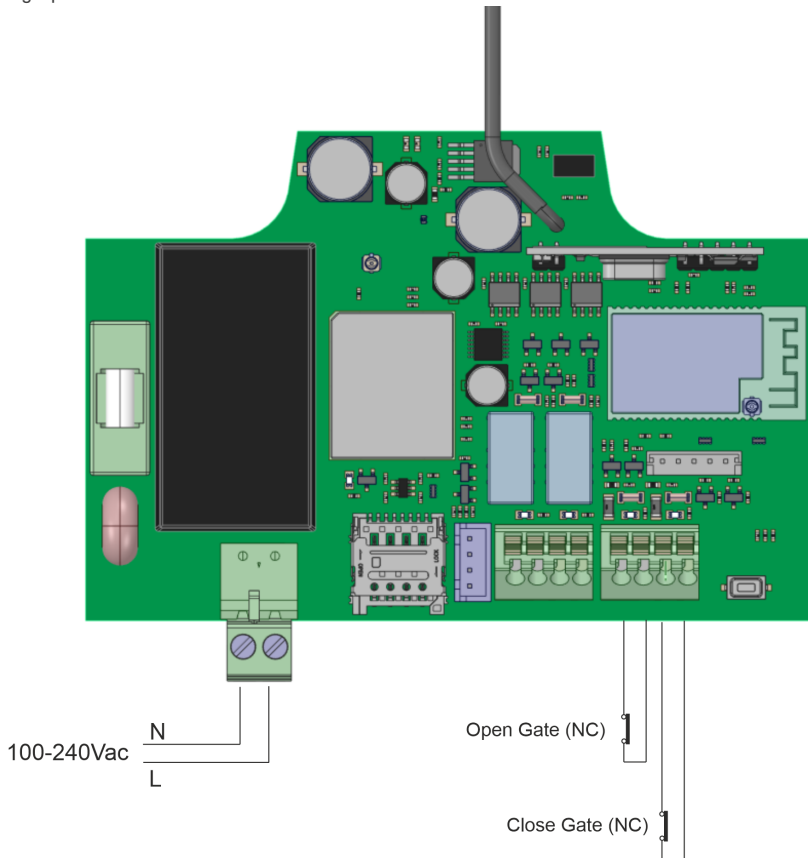

Electric lock or suction cups

The relays can switch up to 2A of resistive loads. The number of manoeuvres depends on the type and characteristics of the loads.

With resistive loads, they can reach 1000000 manoeuvres with 30W loads.

DC inductive loads: 30W / 30Vdc / 1A -> 500000 manoeuvres. One diode (1N4007) along with the electric lock or suction cups is necessary in parallel.

Example relay connection 1:

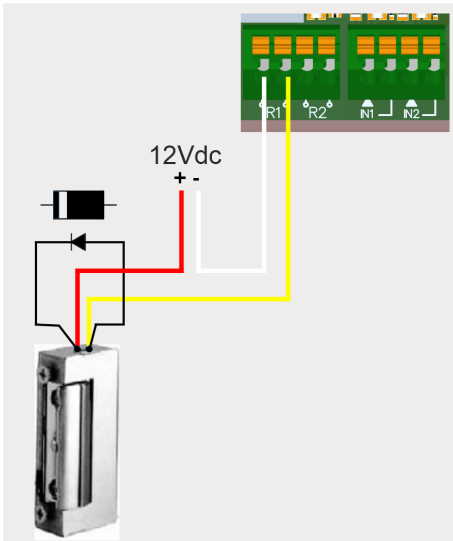

AC inductive loads: 30Va / 30Vac / 1A -> 750000 manoeuvres. A varistor (V68ZA2) with electric lock or suction cups is necessary in parallel.

Example relay connection 1:

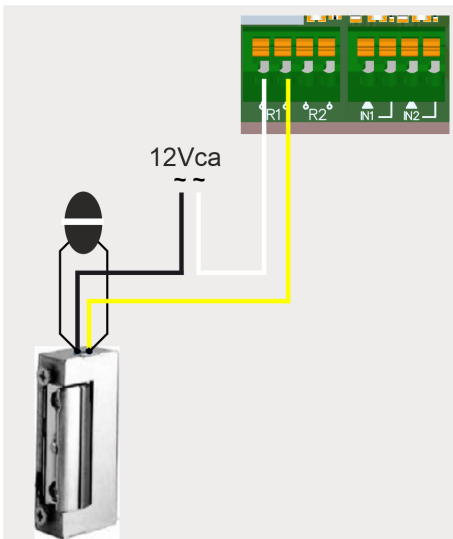

! If using suction cups, the relay type must be "Normally closed" (see: "Configuring relays and assigning traffic schedules").

! The diode or varistor must be connected as close as possible to the electric lock or suction cup.

Configuration

Connect to the Internet

The device must be connected to the Internet to change its settings, but it does not require a connection to function.

The device comes with a SIM card supplied: power on the device and wait about 5 minutes until it connects to the Internet (LEDs solid green).



Configuration with cloudAssistant

Registering the equipment

Once the equipment has an Internet connection, it can be configured:

1. Enter cloudAssistant:<https://cloudassistantv4.jcm-tech.com/login> and login.
2. **Add facility** (orange button located in the lower right corner).

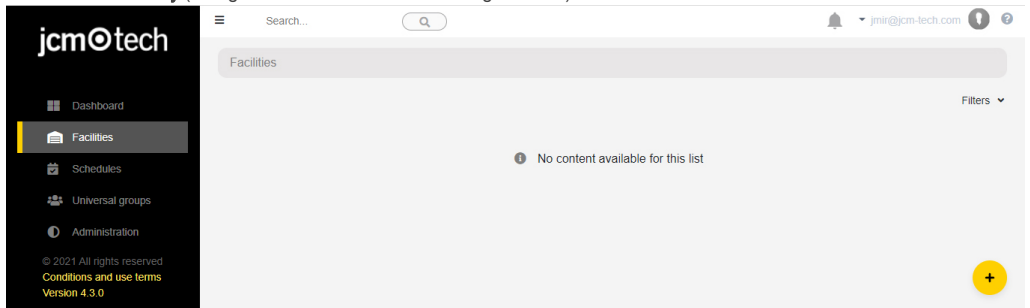

3. Fill the fields. **Save.**

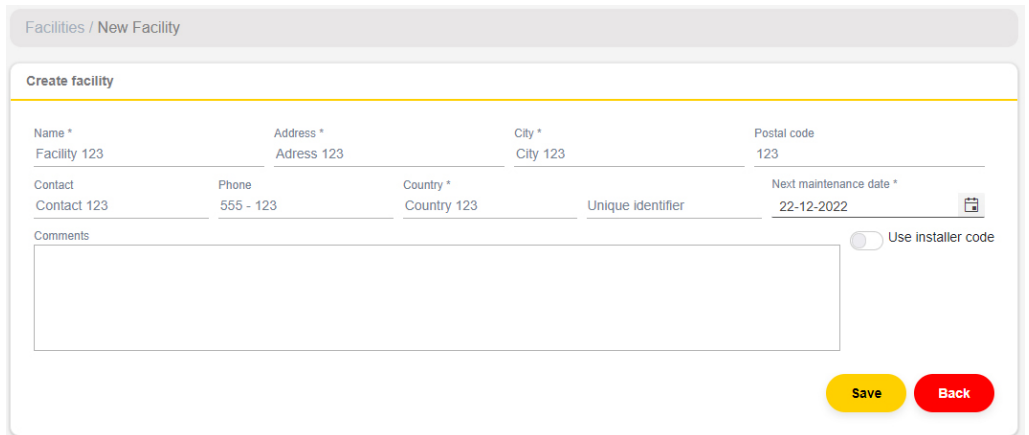
A screenshot of the 'Create facility' form in the cloudAssistant web interface. The form is titled 'Facilities / New Facility' and 'Create facility'. It contains several input fields: 'Name *' (Facility 123), 'Address *' (Address 123), 'City *' (City 123), and 'Postal code' (123). Below these are 'Contact' (Contact 123), 'Phone' (555 - 123), 'Country *' (Country 123), 'Unique identifier', and 'Next maintenance date *' (22-12-2022). There is a 'Comments' text area and a toggle switch for 'Use installer code'. At the bottom right are 'Save' and 'Back' buttons.

The name of the installation and the city will appear in the HONOA APP:

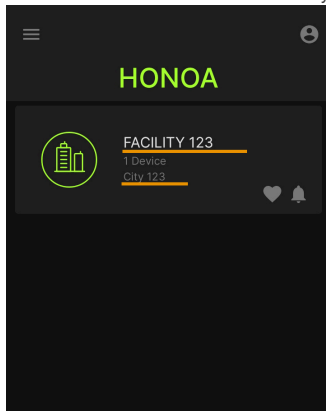

4. **Equipments** -> **Add equipment** (orange button located in the lower right corner).

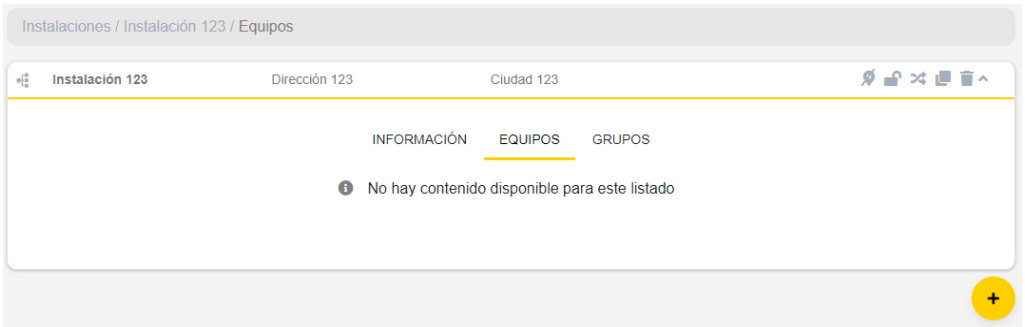

5. Enter a name for the device and select HONOADOOR. **Save**.

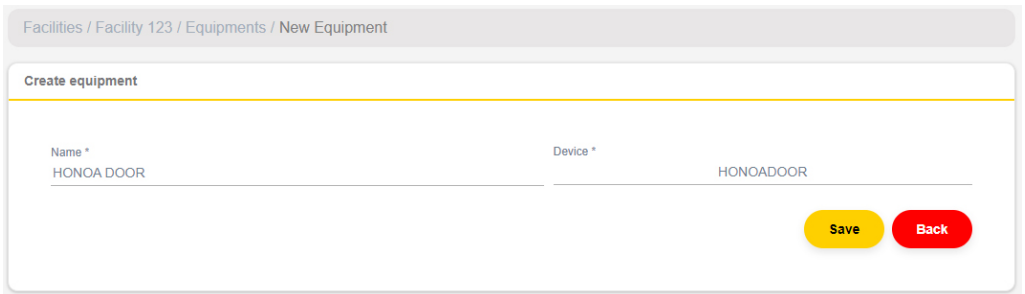

One facility supports a maximum of 25 HONOADOOR and HONOARELAY devices in total.

The name of the device will appear in the HONOA APP:

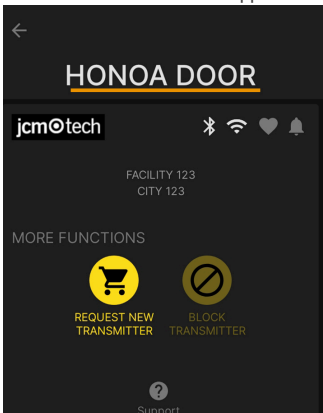

- Enter the **Activation Key** (found in the device label). Select the pertinent **Timezone** and assign names and work modes to the entries. **Save**.

The names assigned to the entries are the same ones that appear in "Remote state" (see: Operational Mode).

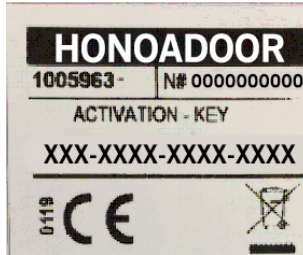

HONOA DOOR
🔴 🖨️ 🗑️ ↕️

Name *
HONOA DOOR

Device *
HONOA DOOR

Parameters
Relays
Fobs
Groups
Events

Activation key	1Si8-vJcA-Vso4-BEzu
Active group on FREE system	No
Group number on FREE system	0
Group 0 on FREE system blocked	No
Data usage	Low
Timezone	Europe/Madrid
Anti-Passback Mode (APB)	Unused
Anti-passback reset time in hours (Anti-timeback)	0
HONOA Allow remote opening	Yes
HONOA Allow BlueTooth hands-free	Yes
Input 1 name	Open door
Input sensor 1 mode	[Door 1] Normally closed opening limit switch
Input 2 name	Close door
Input sensor 2 mode	[Door 1] Normally closed closing limit switch

Save
Back

The Activation key and the Timezone are the only mandatory fields to register users.
!

On this screen, you may enable **Allow remote opening** and **Allow BlueTooth hands-free** for HONOA users. By default, these are enabled.

For remote opening, the device must be connected to the Internet.

Registering groups and users

1. **Groups** -> **Add** (orange button located in the lower right corner).

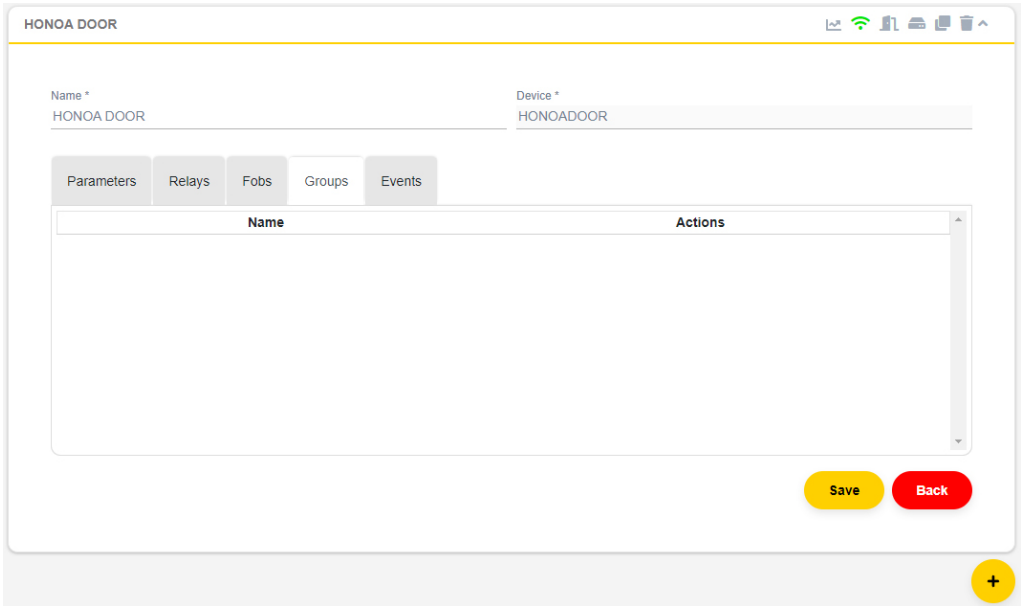

The screenshot shows a web interface for configuring a HONOA DOOR. At the top, the title "HONOA DOOR" is displayed on the left, and system status icons (signal, Wi-Fi, battery, printer, trash, and refresh) are on the right. Below the title, there are two input fields: "Name *" with the value "HONOA DOOR" and "Device *" with the value "HONOADOOR". A horizontal menu contains five tabs: "Parameters", "Relays", "Fobs", "Groups", and "Events", with "Groups" currently selected. Below the tabs is a table with two columns: "Name" and "Actions". The table is currently empty. At the bottom right of the main content area, there are two buttons: a yellow "Save" button and a red "Back" button. A yellow circular button with a plus sign is located at the bottom right corner of the interface.

2. Enter Name and Description. **Save**.

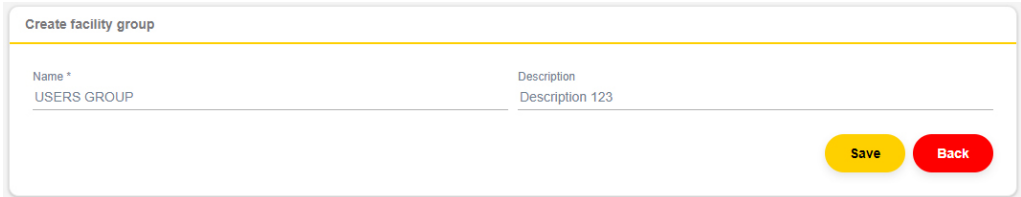

The screenshot shows a form titled "Create facility group". It has two input fields: "Name *" with the value "USERS GROUP" and "Description" with the value "Description 123". At the bottom right of the form, there are two buttons: a yellow "Save" button and a red "Back" button.

3. Activate the relays by selecting any of the channels. HONOA activates relays. **Back**.

Facilities / Facility 123 / Groups / USERS GROUP / Configuration

Relays Schedules

USERS GROUP

HONOA DOOR

OPEN CLOSE

- Channel: 1
- Channel: 2
- Channel: 3
- Channel: 4

Back

If this is a group of devices working with fobs, the selected channels match the function that the fob will have.

4. On the group screen: **Enroll code** to add fobs.

Facilities / Facility 123 / Groups / USERS GROUP

USERS GROUP

FOBS WIEGAND USERS INFORMATION

Available **5000** Not assigned **0** Used **0**

Alarm	Code	Type	Name	Surname	Identity c...	Slot
	<input type="text"/>	<input type="text"/>	<input type="text"/>	<input type="text"/>	<input type="text"/>	<input type="text"/>

There is no data available.

Enroll code

Back

5. **Manual** to add one by one, **Sequential** to add a series of fobs. Fill in the fields correctly, enter the serial number correctly. **Accept**.

Facilities / Facility 123 / Groups / USERS GROUP / Enroll process

Manual Sequential Reservations

Available **5000** Not assigned **0** Used **0**

Device *	MUVPRO4	Code *	381077
Name	Name 123	Surname	Surname 123
Identity card	123	Slot	15

Accept Back

This equipment does not work with reservation codes and does not allow replacements. All fobs must be directly managed with the equipment's memory with the button Save configuration.

6. On the group screen: **Add user** to add HONOA users.

Facilities / Facility 123 / Groups / USERS GROUP / Users

USERS GROUP

FOBS WIEGAND USERS INFORMATION

Available **5000** Used **0**

<input checked="" type="checkbox"/>	Email	Name	Surname	Phone	From	To			
	🔍	🔍	🔍	🔍	🔍	🔍			

There is no data available.

⏪ ⏩ ⏴ ⏵

⬇️ ⬆️

Add user

+

Back

7. Complete the fields with the user information. **Accept.** The different users must provide the email used for their Honoa account.

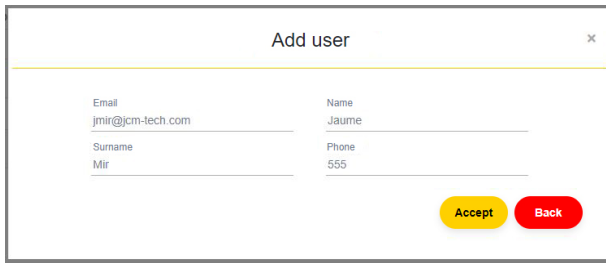

Add user

Email
jmir@jcm-tech.com

Name
Jaume

Surname
Mir

Phone
555

Accept Back

When a user is registered with cloudAssistant, they will automatically have access to the installation with the Honoa application. 

8. Click "Installation Name" in the upper gray bar to go to installation.

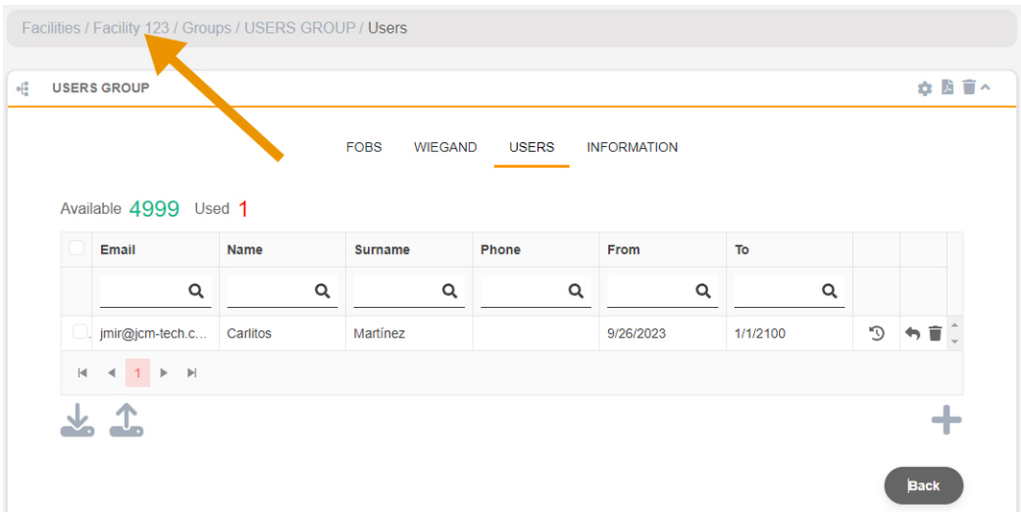

Facilities / Facility 123 / Groups / USERS GROUP / Users

USERS GROUP

FOBS WIEGAND USERS INFORMATION

Available 4999 Used 1

<input type="checkbox"/>	Email	Name	Surname	Phone	From	To			
<input type="checkbox"/>	jmir@jcm-tech.c...	Carlitos	Martinez		9/26/2023	1/1/2100			

Back

9. Equipments -> Save configuration.

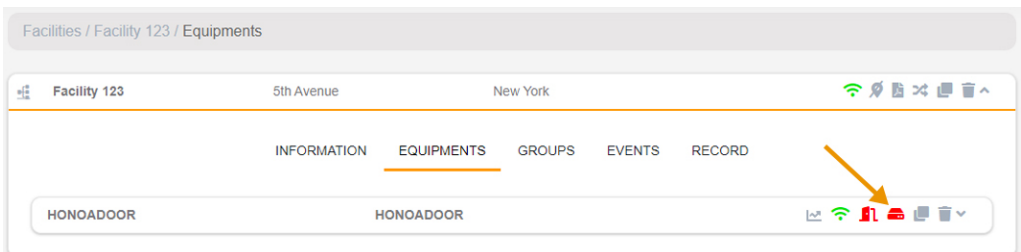

Facilities / Facility 123 / Equipments

Facility 123 5th Avenue New York

INFORMATION EQUIPMENTS GROUPS EVENTS RECORD

HONOADOOR HONOADOOR

Save configuration



Every time an equipment parameter is modified, you must Save configuration.

It is not necessary to press Save configuration to update HONOA user authorizations.

Configure relays and assign traffic schedules

On the equipment's "Relays" screen:

Information	Parameters	Relays	Fobs	Groups	Events
Relay 1 OPEN	<input checked="" type="checkbox"/>	Relay type 1 Normally open	Relay 1 activation time 1 s	Open door schedule --	Custom open door time schedule --
			Relay 1 delay time 0 s		Door open time 5 s
Relay 2 CLOSE	<input checked="" type="checkbox"/>	Relay type 2 Normally open	Relay 2 activation time 1 s	Open door schedule --	Custom open door time schedule --
			Relay 2 delay time 0 s		Door open time 1 s

Save

- **Relay X:** assign name to the relay
- **Selector:** enable/disable relay
- **Relay type X:** Normally open/ Normally closed
- **Relay activation time X:** set the time that the relay remains active for (it is 1 second by default)
- **Relay delay time X:** set the time that it takes for the relay to activate (it is 0 seconds by default)
- **Open door schedule:** The relay activates automatically, based on the assigned weekly hours. Without assigned hours, the relay operates normally
- **Custom open door time schedule:** Activation time goes from 1 second to the time selected in "Door open time", based on the assigned weekly hours. Without assigned schedules, the relay operates normally
- **Door open time:** time in seconds

For the activation times and schedule to work, the device must be connected to the Internet.



Every time an equipment parameter is modified, you must save configuration.

The relay names are displayed in the HONOA APP:

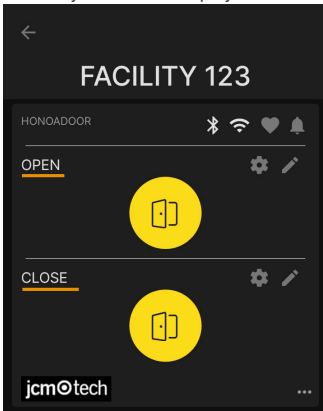

Set group schedules

The assignment of a schedule to a group is done in the "Configuration" screen of groups:

Facilities / Facility 123 / Groups / USERS GROUP

Configure

USERS GROUP

FOBS WIEGAND USERS INFORMATION

Available 4999 Not assigned 0 Used 1

Alarm	Code	Type	Name	Surname	Identity c...	Slot
	381077	MUVPRO4	Name 123	Surname 123	123	15

Back

Facilities / Facility 123 / Groups / USERS GROUP / Configuration

Relays Schedules

HONOA DOOR

OPEN
USERS

CLOSE
USERS

Back

Group users can only activate the relay when within the assigned hours. If there is no assigned schedule, it can always be activated.

For the schedule to work, the device must be connected to the Internet.



Every time an equipment parameter is modified, you must save configuration.

Administration: Honoa

HONOA users may view your contact information by clicking on the logo to the bottom left of the device in the HONOA APP. Contact information can be changed on the "Honoa" screen under "Administration".

Administration / Honoa

Web customization | Invitations | Companies | Users | Holidays | Honoa

Customize device information for app HONOA

jcmotech

Logo *

E-mail *
jmir@jcm-tech.com

Phone *
555 - 555

City *
City 123

jcmotech

Collapsed logo

Web *
website.com

Address *
Address 123

Mobile preview

jcmotech

Address 123
City 123
555 - 555
jmir@jcm-tech.com
website.com

Save Back

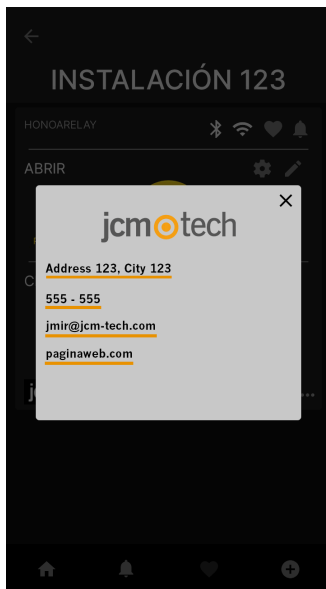

Events

HONOADOOR is a device with an event record. To see them, in **cloudAssistant**, go to the device's **"Events"** screen. Events are stored locally on the device. When HONOADOOR does not have an internet connection, the device keeps working, but it cannot read the events. To load the list of events from the device, go to the **"Events"** screen → **"Load events"**. To read the events, the device must be connected to the Internet.

Facilities / Facility 123 / Equipments / HONOADOOR / Events

HONOADOOR HONOADOOR

Information Parameters Relays Codes Groups Events

Date	Event	User	Code	Group	Additional info...

There is no data available.

Load events Delete events

To reset the device's list of events, select **"Remove events"**.

Facilities / Facility 123 / Equipments / HONOADOOR / Parameters

HONOADOOR HONOADOOR

Information Parameters Relays Codes Groups Events

- HONOA Allow remote opening Yes
- HONOA Allow BlueTooth hands-free (BETA) Yes
- Wiegand configuration ⚙️
- Event settings ⚙️

List of available events:

- Access denied / Fob not programmed or disabled
- Access denied/Tag/Wiegand not programmed or disabled
- Access denied / Suspicious transmitte
- Access denied / Out of calendar
- Access denied / Wrong channel
- Access denied / APB
- Access granted
- Door open/closed
- Access granted / Button
- Safety input activated
- Power on
- Eventlog reset
- FOTA

Operational mode

Remote control from cloudAssistant

To control the equipment remotely it is necessary to have it connected to the Internet:

- Go to "**Facilities**" -> "Facility name" -> "**Equipments**"-> Select "**Remote State**" (button with the door).

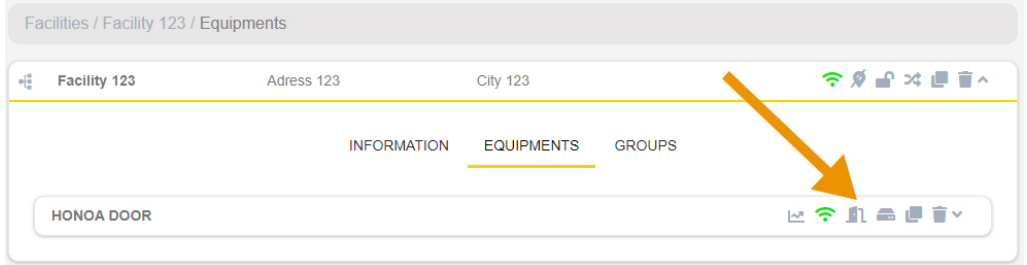

Remote state

Door status 1

Status Closed

Input status

Open door

Close door

Relays

OPEN activation time in sec 1

CLOSE activation time in sec 1

Device information

Device type	HONOADOOR / EBASEDOOR
Connection type	WiFi
Connection signal	Excellent
RSSI Value	-45 dBm
Hardware version	EBASEDOOR_02
Software version	00.00.06.15

We can view the status of the inputs and remotely activate the equipment's relays. You also have information on the equipment (equipment versions, connection levels, etc.).

Anti-Passback

HONADOOR can operate with Anti-Passback. **The Anti-Passback feature only works with MOTION tags and fobs (with compatible references).**

The Anti-Passback is to monitor passage, preventing a user from entering twice consecutively in the same direction. The user must enter once in each direction (entry and exit).

MODE 0:

Mode 0 always returns OK permission to conduct the manoeuvre.

The timeback has no effect on this mode.

MODE 1:

Mode 1 is designed for one single access that works as both entry and exit at once.

- Both loops are mandatory and indicate whether the code received is entering or exiting.
- The received channel does NOT define entry or exit.
- After the timeback as run out after a movement, the code goes into undefined status, allowing for all operations.
- Exit is always allowed, regardless of status, provided that the matching loop is active.
- Channel received does not matter.

MODE 2:

Identical to Mode 1, but free exit is not allowed. Exit is only allowed if the spot is occupied. (status = INSIDE).

- Both loops are mandatory and indicate whether the code received is entering or exiting.
- The received channel does NOT define entry or exit.
- After the timeback as run out after a movement, the code goes into undefined status, allowing for all operations.
- Exit is only allowed when the status is INSIDE, provided that the matching loop is active.
- Channel received does not matter.

MODE 3:

Mode 3 is designed for one single access that works as both entry and exit at once.

The entry may have proximity readers (in this case, the magnetic loops are not read), or operate with fobs and loops.

Proximity entry:

- The entry's proximity reader must be set as channel 1. It acts as a presence-detecting loop for the entry.
- The exit's proximity reader must be set as channel 2. It acts as a presence-detecting loop for the exit.

You must remember to properly set the channel-relay relationship in the central based on the installation; in other words, if using only one relay for channels 1 and 2, or the relay 1 and the 2 (multi-channel registrations) bypassed in parallel to activate the panel.

If the entry does NOT have proximity readers, it is mandatory to have magnetic presence-detection loops.

Access with fob:

For entry, channel 1 of the fob must be controlled. To exit, channel 2 of the fob must be controlled. Channels 3 and 4 are not controlled by the APB, because this card always returns the OK manoeuvre for channels 3 and 4. The status of the loops will be read to know the direction of the manoeuvre and to give permission or deny the manoeuvre.

- The entry loop is mandatory to enter with a fob.
- The exit loop is mandatory to exit with a fob.

There are three status for each memory position: INSIDE, OUTSIDE, UNDEFINED.

If timeback is greater than 0, after it has run out after a correct manoeuvre, it moves to UNDEFINED STATUS.

If timeback is 0, the APBK works absolutely, without time control.

The enter, it checks that the code is on OUTSIDE or UNDEFINED status.

The exit, it checks that the code is on INSIDE or UNDEFINED status.

MODE 4:

Mode 4 is designed for a situation with physically separated entrance and exit.

Access points may have proximity readers (in this case, the magnetic loops are not read).

- The entry's proximity reader must be set as channel 1 or 3.
- The exit's proximity reader must be set as channel 2 or 4.

Remember to correctly set the channel-relay relationship at central based on the installation.

If the access points do NOT have proximity readers, it is mandatory to have magnetic presence-detection loops.

As such, to enter, the channel received from the fob and the activated loop will be controlled. Channels 1 and 3 are associated with the entry. 2 and 4 with the exit.

The status of the loops will be read to grant or deny permission for the movement.

In both cases, there are three status for each memory position: INSIDE, OUTSIDE, UNDEFINED.

If timeback is greater than 0, after it has run out after a correct manoeuvre, it moves to UNDEFINED STATUS.

If timeback is 0, the APBK works absolutely, without time control.

Sketch HONOADOOR installation with layout of inputs Anti-Passback mode operation with magnetic Entry/Exit detectors:

POWER INPUT: Power supply at 230Vac.

R1:RELAY Channel 1. Potential-free contact.

R2: RELAY Channel 2. Potential-free contact

- Characteristics of output relays (for resistive load):
- Maximum current: 2A.
- Maximum power: 60W / 62.5VA.
- Maximum voltage: 24V ac/dc.

IN 1: Exterior magnetic detector open-contact input.

IN 2: Interior magnetic detector open-contact input.

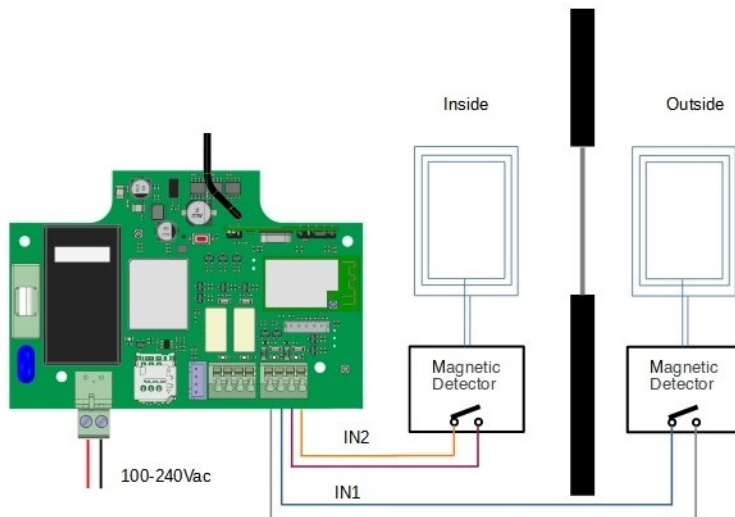

Settings in cloudAssistant

Facilities / Facility 123 / Equipments / HONOA DOOR / Parameters

HONOA DOOR

Name *
HONOA DOOR

Device *
HONOADOOR

Parameters Relays Fobs Groups Events

Timezone	Europe/Madrid
Anti-Passback Mode (APB)	Mode 1 (1 entry/exit door)
Anti-passback reset time in hours (Anti-timeback)	0
HONOA Allow remote opening	Yes
HONOA Allow Bluetooth hands-free	Yes
Input 1 name	Anti-Passback in
Input sensor 1 mode	Input APB normally open
Input 2 name	Anti-Passback out
Input sensor 2 mode	Output APB normally open

Save Back

The Anti-timeback is a timed Anti-Passback. It allows two consecutive entries in the same direction after the selected time has passed. By default to 0 (without Anti-timeback).

Verification

LED behaviour



OFF



FIXED



BLINKING

State	Status LED	Network LED	Internet LED	Action
Power off				-
No Firmware				CALL TECHNICAL SUPPORT
Starting				WAIT
GSM Configuring				Use embedded web or WPS to configure connectivity
GSM Configuring timeout				Reset device
Connecting GSM				WAIT
GSM Error				WRONG GSM PASSWORD
Internet Connecting				WAIT
Internet Error				CHECK ROUTER (INTERNET)
JCM Cloud Connecting				WAIT
JCM Cloud Error				CALL TECHNICAL SUPPORT
Ready				-
Reset				Keep reset button pressed
Update				WAIT
Communicating				-

Solving problems

Resolve reception issues

In the event that the equipment does not have optimum reception where it is installed, you may purchase one of the following antenna boosters by contacting your regular supplier:

1. BLE -> 1007315_BLE_ANT_2M
2. GSM/2G/LTE -> 1007316_MLTE_ANT_3M

Technical data

Parameter	Value
Power Supply	100 - 230Vac
Stand-by / operating consumption	0,250A / < 0,001A
Relay Contacts (R1 / R2)	2A Resistive load
Operating temperature	-20°C / +55°C
Size (L/W/H)	140 x 220 x 55mm
Watertightness	IP54 (with cable gland IP65)
Operating frequencies	868MHz
Coding	High security changing code
Memory	5000 codes
GSM network type	LTE Cat M1/Cat NB2/EGPRS
Network type	BLE

Regulatory Data

UKCA Declaration of conformity

The manufacturer **JCM TECHNOLOGIES, SAU** declares that the product **HONOADOOR** complies with the relevant fundamental requirements of the Radio Equipment Regulations 2017 and of the RoHS Regulations 2012.

EU Declaration of conformity

The manufacturer **JCM TECHNOLOGIES, SAU** declares that the product **HONOADOOR** complies with the relevant fundamental requirements of the RED Directive 2014/53/EU and of the RoHS Directive 2011/65/EU.

See website <https://www.jcm-tech.com/declarations/>

JCM TECHNOLOGIES, SAU
C/ COSTA D'EN PARATGE, 6B
08500 VIC (BARCELONA)
SPAIN

